

OPTIMIZATION ALGORITHMS M

Paolo Toth (paolo.toth@unibo.it) 051 2093028

Office hours: Wednesday, 11-13, DEI (Second Floor)

Alberto Santini (alberto.santini@upf.edu)

Office hours: contact through an e-mail message

Course Objectives

The objective of the course is to **present the most effective techniques for the solution of complex *decisional problems*** arising in the optimal planning and management of large scale systems.

Mathematical models and exact algorithms for the practical solution of the corresponding Combinatorial Optimization problems will be described.

Particular attention will be given to the algorithmic and implementation aspects.

The evaluation of the performance of the considered models and algorithms will be performed through ***computational experiments***.

Course description and structure

1. Classification of the *Optimization Problems*.
2. Definition of the *Mathematical Models*, and analysis of the corresponding *Computational Complexity*, of some important *Combinatorial Optimization problems*.
3. Study of a commercial software (**Package CPLEX**) for the solution of *Linear Programming (LP)* and *Mixed Integer Linear Programming (MILP)* models.

Course description and structure (2)

4. Exact algorithms for the solution of *NP-Hard Combinatorial Optimization problems*:

"Branch-and-Bound" algorithms: decision trees, relaxation techniques, improvement of the relaxed problems, subgradient optimization technique, dominance criteria, reduction procedures, "core problem" technique.

Exact algorithms for the effective solution of the 0-1 Knapsack Problem (KP-01), the Set Covering Problem (SCP), and the Asymmetric Travelling Salesman Problem (ATSP).

5. ***"Branch-and-Cut" algorithms***: addition of valid constraints for the strengthening of the relaxed problems, separation procedures for the solution of models with a large number of constraints.

Exact algorithms for the effective solution of the ATSP.

Course description and structure (3)

6. "*Branch-and-Price*" algorithms: pricing and column generation procedures for the solution of models with a large number of decisional variables.

Exact algorithms for the effective solution of the Bin Packing Problem (BPP) and of the Vertex Coloring Problem (VCP).

7. *Experimental evaluation* of the computational performance of the proposed models and algorithms.

Basic knowledge of Computer Science and Operations Research courses are required.

Teaching material

The teaching material, covering all the lessons of the course, will be available on the site

<http://santini.in/oa/>

Relevant References

- **S. Martello, P. Toth, *Knapsack Problems: Algorithms and Computer Implementations*, J. Wiley, 1990.**
- **G. Gutin, A. Punnen (editors), *The Traveling Salesman Problem and Its Variations*, Kluwer, 2002.**
- **C. Barnhart, G. Laporte (editors), *Transportation, Handbooks in Operations Research and Management Science*, North Holland, 2007.**
- ***Wiley Encyclopedia in Operations Research and Management Science*, Wiley, 2011.**
- **P. Toth, D. Vigo (editors), *Vehicle Routing: Problems, Methods and Applications*, MOS-SIAM Series on Optimization, 2014.**

Student Evaluation

Three independent parts:

Part 1: Mathematical Models, Computational Complexity (30);

Part 2: Relaxations, Exact Algorithms (30);

Laboratory: CPLEX Package (5), not compulsory.

Global score = (sum of the three scores) / 2

Final written tests at the end of the course (only Part 1 and Part 2):

*** January 15, 2019, 10:00 a.m. (Room 5.6);**

*** February 18, 2019, 10:00 a.m. (Room 5.6).**

Student Evaluation (2)

Three “not compulsory exercises” (“self assessment evaluation tests”) will be proposed:

- * Part 1: November XX, 2018;**
- * Laboratory: December XX, 2018;**
- * Part 2: December 18, 2018, 10:00 a.m.
(Room 5.6).**

The “not compulsory exercises” can be carried out in place of the corresponding final written tests.

Optimization Problems

- **Choice**, among different alternatives, of the **set of decisions** to obtain the best performance from the considered system.
- **Example: Production Plant .**

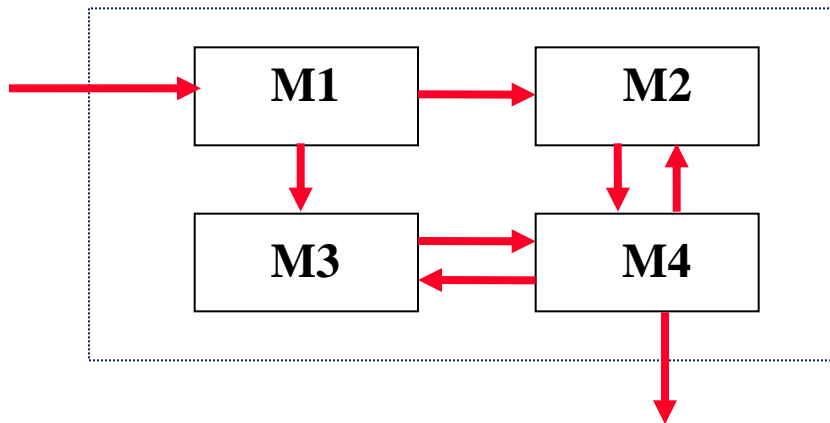

The plant produces a set of items which must be processed, in a given order, on the machines.

Optimization Problems (2)

The plant produces a set of items which must be processed, in a given order, on the machines.

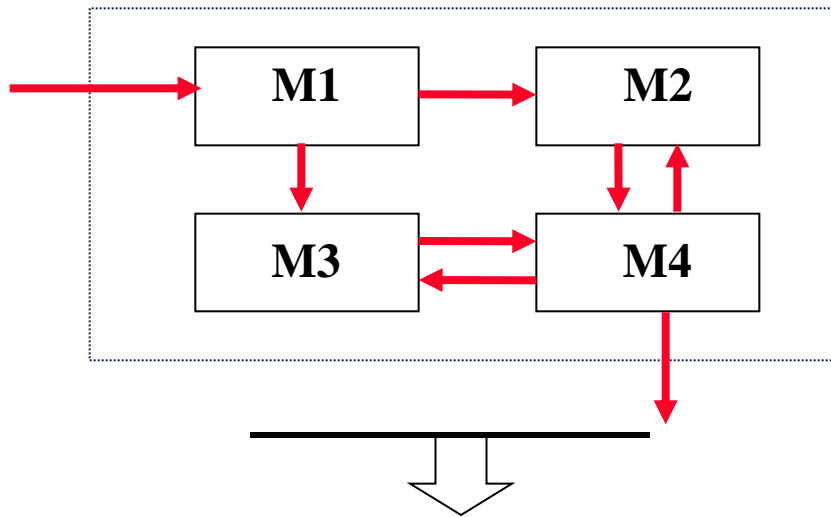

Decisions:

Plant layout

Machine choice

Item sequencing

Performances: max productivity, min cost, min time, ...

Optimization Problems (3)

Strategic Level (*Planning*)

- Long term time period
- Probabilistic environment (forecasting of the market requests), different alternative scenarios
- **Ex.** plant layout, machine choice, ...

Operational Level (*Management*)

- Short term time period
- Dependence on the strategic level choices
- Deterministic environment (**Ex.** list of the items to be produced)

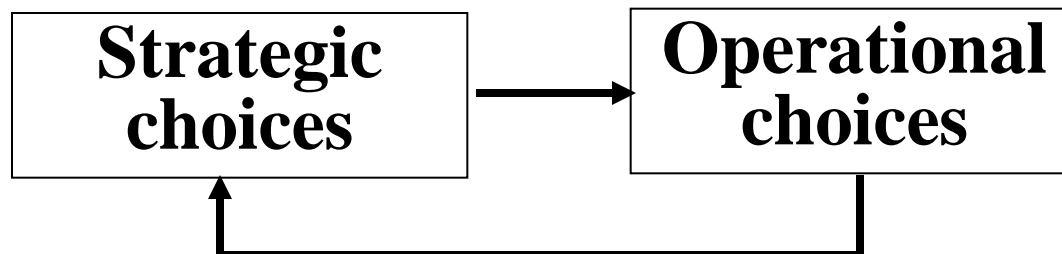

Optimization Problems (4)

Objective:

“measure” of the **quality** (performance) of a solution.

Constraints:

“conditions” to be satisfied to obtain a **feasible solution**”.

Optimization Problem:

Find a **feasible solution** which **minimizes** (or **maximizes**) the **objective**.

Multi-Objective Optimization Problems.

Applications of the Optimization Models and Algorithms

- **Strategic problems**
 - **Capital investment**
 - **Location of plants (factories, depots, airports, arbors, railway stations, schools, hospitals, fire stations, ...)**
 - **Sizing of plants, personnel, fleets, ...**
 - **Network design (telecommunication, road, railway, ...)**
 - ...

Applications of the Optimization Models and Algorithms (2)

- **Operational problems**
 - Assignment of jobs to machines
 - Job sequencing
 - Production Line balancing
 - Vehicle routing and scheduling
 - Staff scheduling
 - Train and bus timetabling
 - Loading of vehicles, containers, pallets, ...
 - Cutting of wood, glass, cloths, ...
 - ...

MATHEMATICAL MODELS

- n decisional (*numerical*) variables:

$$x_1, x_2, \dots, x_n$$

- objective function:

$$f(x_1, x_2, \dots, x_n)$$

- m constraints (*Feasible Region*):

$$g_i(x_1, x_2, \dots, x_n) \leq b_i \quad i = 1, 2, \dots, m$$

$f(\mathbf{x})$ and $g_i(\mathbf{x})$ ($i = 1, 2, \dots, m$) algebraic functions of x_1, x_2, \dots, x_n

MATHEMATICAL MODELS (2)

Given:

$$Z = \max f(x_1, x_2, \dots, x_n)$$

subject to:

$$g_i(x_1, x_2, \dots, x_n) \leq b_i \quad i = 1, 2, \dots, m$$

$$x_j \geq 0 \quad j = 1, 2, \dots, n$$

Find the optimal solution: $x_1^*, x_2^*, \dots, x_n^*$ so that:

- 1) All the m constraints are satisfied (feasible solution);
- 2) The value of the objective function is maximized.

MATHEMATICAL MODELS (3)

- The decisional variables x_1, x_2, \dots, x_n can be
 - continuous (any value within a given interval),
 - discrete (finite number of possible values),
 - continuous and discrete:
- CONTINUOUS OPTIMIZATION PROBLEM,
- COMBINATORIAL OPTIMIZATION PROBLEM,
- MIXED OPTIMIZATION PROBLEM.

OPTIMIZATION ALGORITHMS

- Different algorithms must be used, according to the type of the optimization problem to be solved.
- **Exact algorithms (find an optimal solution)**
- **Heuristic algorithms (find a “good” feasible solution)**
- **In both cases we wish to obtain**
“efficient” algorithms (short computing times)

CONTINUOUS OPTIMIZATION

- **LINEAR PROGRAMMING (LP)**
- **NONLINEAR PROGRAMMING (NLP)**

LINEAR PROGRAMMING (LP)

$f(x)$ and $g_i(x)$ ($i = 1, 2, \dots, m$) are all linear functions:

$$f(x) = p_1 x_1 + p_2 x_2 + \dots + p_n x_n = \sum_{j=1, n} p_j x_j$$

$$g_i(x) = a_{i1} x_1 + a_{i2} x_2 + \dots + a_{in} x_n = \sum_{j=1, n} a_{ij} x_j \quad (i = 1, \dots, m)$$

Example (Linear Programming)

$$\max Z = 6x_1 + 5x_2$$

$$x_1 \leq 4$$

$$x_2 \leq 6$$

$$3x_1 + 2x_2 \leq 18$$

$$x_1 \geq 0, x_2 \geq 0$$

$$n = 2, m = 3$$

$$p_1 = 6, \quad p_2 = 5$$

$$a_{11} = 1, a_{12} = 0, a_{21} = 0, a_{22} = 1, a_{31} = 3, a_{32} = 2$$

$$b_1 = 4, b_2 = 6, b_3 = 18$$

LINEAR PROGRAMMING (2)

$$(LP) \quad Z = \max \sum_{j=1, n} p_j x_j$$

s.t.

$$\sum_{j=1, n} a_{ij} x_j \leq b_i \quad (i = 1, \dots, m)$$

$$x_j \geq 0 \quad (j = 1, \dots, n)$$

SIMPLEX ALGORITHM (Dantzig)

Problems with thousands of variables and constraints can be solved in short computing times (“exponential” time in the worst case).

ELLIPSOID ALGORITHM (Karmarkar)

“Polynomial” time in the worst case (on average, less effective than the Simplex Algorithm).

NONLINEAR PROGRAMMING (NLP)

- At least one among $f(x)$ and $g_i(x)$ ($i = 1, 2, \dots, m$) is a **nonlinear function**.
- The problem is **DIFFICULT** to be solved (the corresponding computing time depends on the number and type of the nonlinearities).
- Exact and heuristic algorithms.
- * **LINEARIZATION** of the nonlinear functions.

COMBINATORIAL OPTIMIZATION

EXAMPLE:

INTEGER LINEAR PROGRAMMING

$$\text{(ILP)} \quad Z = \max \sum_{j=1, n} p_j x_j$$

s.t.

$$\sum_{j=1, n} a_{ij} x_j \leq b_i \quad (i = 1, \dots, m)$$

$$x_j \geq 0 \quad (j = 1, \dots, n)$$

$$x_j \leq d_j \quad (j = 1, \dots, n)$$

$$x_j \quad \text{integer} \quad (j = 1, \dots, n)$$

COMBINATORIAL OPTIMIZATION (2)

COMPLETE ENUMERATION

* consider all the possible combinations of the n decisional variables:

for each combination: check the m constraints and compute the objective function (storing the feasible solution having the maximum value of the objective function).

- number of combinations: $(d_1 + 1) (d_2 + 1) \dots (d_n + 1)$
- If $d_j = 1$ ($j = 1, \dots, n$): 2^n combinations
(binary variables)

MIXED OPTIMIZATION

EXAMPLE

MIXED LINEAR PROGRAMMING

$$\text{(MILP)} \quad Z = \max \sum_{j=1, n} p_j x_j$$

s.t.

$$\sum_{j=1, n} a_{ij} x_j \leq b_i \quad (i = 1, \dots, m)$$

$$x_j \geq 0 \quad (j = 1, \dots, n)$$

$$x_j \leq d_j \quad (j = 1, \dots, n)$$

$$x_j \text{ integer} \quad (j = 1, \dots, k) \quad k < n$$

MIXED OPTIMIZATION (2)

- The difficulty of the problem mainly depends on the number k of integer variables.
- If k is small:
 - consider all the possible combinations of the k integer variables:
 - for each combination solve the corresponding LP problem.

EXACT ALGORITHMS

(Combinatorial Optimization and Mixed Optimization Problems)

- **ENUMERATIVE ALGORITHMS**
- **Commonly used algorithms:**
 - **BRANCH AND BOUND**
 - **BRANCH AND CUT**
 - **BRANCH AND PRICE**
 - **DYNAMIC PROGRAMMING**

EXACT ALGORITHMS (2)

- In the **WORST CASE** the algorithms can require computing times growing **EXPONENTIALLY** with the “size” of the problem to be solved.
- Problems having the same “size” can require computing times which are very different:
- the difficulty depends on the type of the constraints, and sometimes on the **values of the coefficients** (p_j , a_{ij} , b_i).

Optimization Model: Example

- Distribution System**

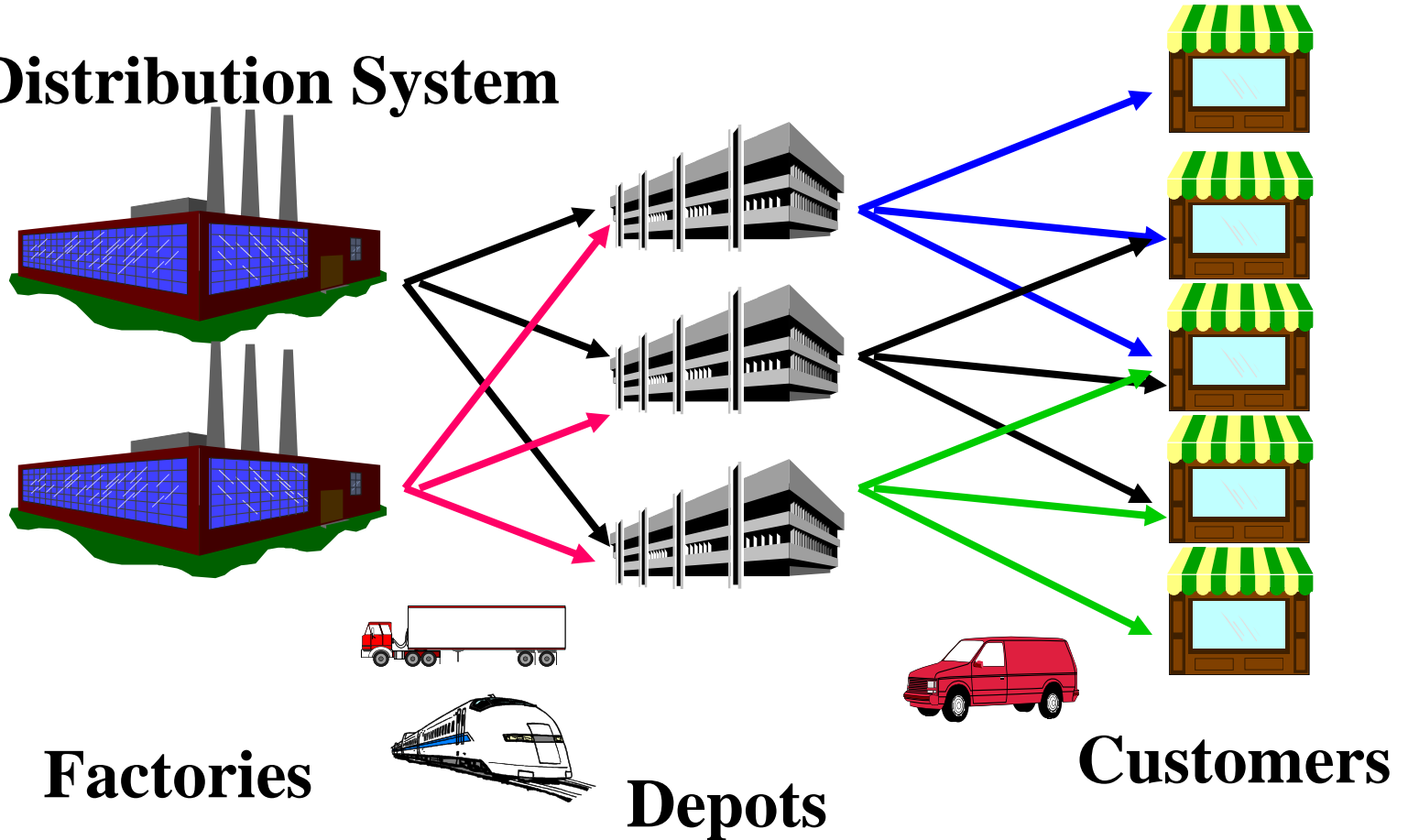

Schematic Model

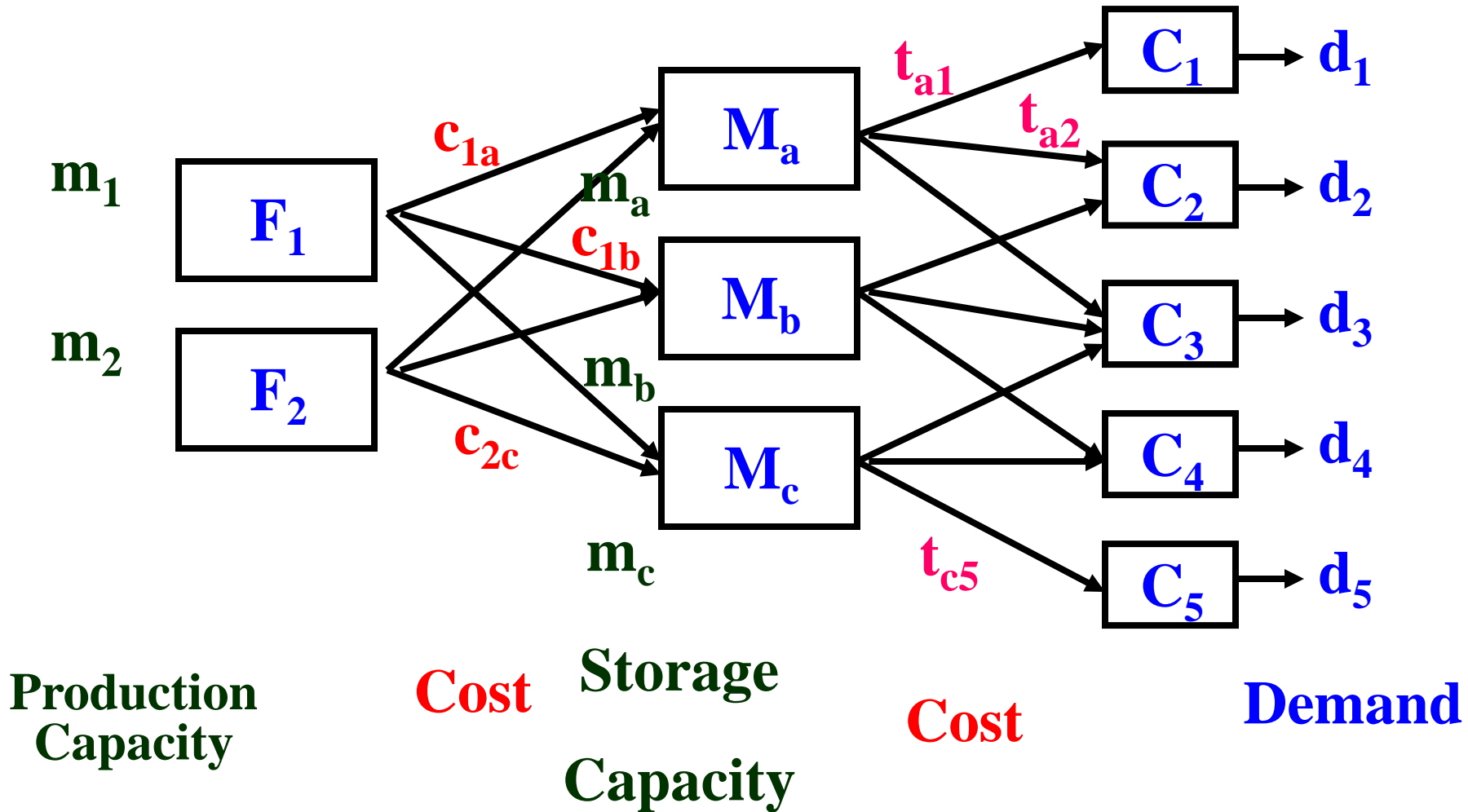

Optimization Problem

- **Minimization of the global transportation cost in a given time period (e.g. 1 day).**
- **Only one product is considered.**
- **The transportation costs are proportional to the quantity of the transported product.**
- **The unit transportation costs are positive**
- **The depots are supposed to be initially empty.**

Mathematical Model

- **Decisional variables:**

x flows from factories to depots ($x \geq 0$)

y flows from depots to customers ($y \geq 0$)

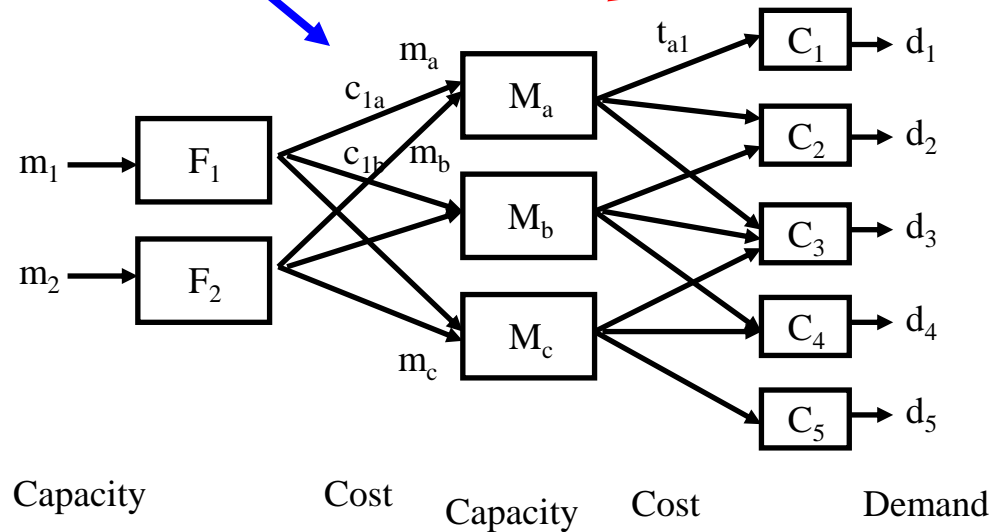

Mathematical Model (2)

(objective function) $\min \quad c_{1a}x_{1a} + c_{1b}x_{1b} + c_{1c}x_{1c} + c_{2a}x_{2a} + c_{2b}x_{2b} + c_{2c}x_{2c} +$
 $t_{a1}y_{a1} + t_{a2}y_{a2} + \dots + t_{a5}y_{a5} + t_{b1}y_{b1} + \dots + t_{c5}y_{c5}$

(capacity constraints)

\forall factory: $x_{1a} + x_{1b} + x_{1c} \leq m_1 \dots$

\forall depot: $x_{1a} + x_{2a} \leq m_a \dots$

(demand constraints)

\forall customer: $y_{a1} + y_{b1} + y_{c1} \geq d_1 \dots$

(flow balance)

\forall depot: $x_{1a} + x_{2a} = y_{a1} + y_{a2} + \dots + y_{a5} \dots$

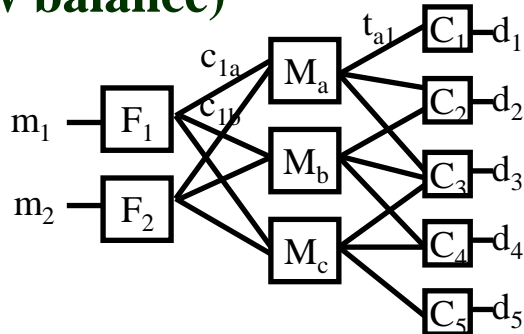

$x \geq 0; \quad y \geq 0$

LINEAR PROGRAMMING PROBLEM